

# OPT Application Guide

Use this guide to compile a complete  
OPT Application to mail to USCIS

Last updated: 11/16/2020



# What is in an OPT Application?

All documents must be printed  
single-sided on standard  
8.5"x11" white paper

## Prepare Your Application Materials

- Optional: Form G-1145 to receive e-Notification of receipt from USCIS
- Check for \$410 Fee
- Original Form I-765
- Photocopy of OPT I-20
- Photocopy of passport biography page
- Photocopy of most recent U.S. visa
- Form I-94
- 2 U.S. Passport photos

*\*Please note: You may need to include other documents in addition to those listed above, depending on your responses in the I-765. See the I-765 Guide for details.*

# What is in an OPT Application?

□ Optional: Form G-1145 to receive e-Notification of receipt from USCIS

 **e-Notification of Application/Petition Acceptance**  
Department of Homeland Security  
U.S. Citizenship and Immigration Services

USCIS  
Form G-1145  
OMB No. 1615-0109  
Expires 09/30/2016

---

**What Is the Purpose of This Form?**

Use this form to request an electronic notification (e-Notification) when U.S. Citizenship and Immigration Services accepts your immigration application. This service is available for applications filed at a USCIS Lockbox facility.

**General Information**

Complete the information below and clip this form to the first page of your application package. You will receive one e-mail and/or text message for each form you are filing.

We will send the e-Notification within 24 hours after we accept your application. Domestic customers will receive an e-mail and/or text message; overseas customers will only receive an e-mail. Undeliverable e-Notifications cannot be resent.

The e-mail or text message will display your receipt number and tell you how to get updated case status information. It will not include any personal information. The e-Notification does not grant any type of status or benefit; rather it is provided as a convenience to customers.

USCIS will also mail you a receipt notice (I-797C), which you will receive within 10 days after your application has been accepted; use this notice as proof of your pending application or petition.

**USCIS Privacy Act Statement**

**AUTHORITIES:** The information requested on this form is collected pursuant to section 103(a) of the Immigration and Nationality Act, as amended INA section 101, et seq.

**PURPOSE:** The primary purpose for providing the information on this form is to request an electronic notification when USCIS accepts immigration form. The information you provide will be used to send you a text and/or email message.

**DISCLOSURE:** The information you provide is voluntary. However, failure to provide the requested information may prevent USCIS from providing you a text and/or email message receipting your immigration form.

**ROUTINE USES:** The information provide on this form will be used by and disclosed to DHS personnel and contractors in accordance with approved routine uses, as described in the associated published system of records notices [DHS-USCIS-007 - Benefits Information System and DHS-USCIS-001 - Alien File (A-File) and Central Index System (CIS), which can be found at [www.dhs.gov/privacy](http://www.dhs.gov/privacy)]. The information may also be made available, as appropriate for law enforcement purposes or in the interest of national security.

**Paperwork Reduction Act**

An agency may not conduct or sponsor an information collection and a person is not required to respond to a collection of information unless it displays a currently valid OMB control number. The public reporting burden for this collection of information is estimated at 3 minutes per response, including the time for reviewing instructions and completing and submitting the form. Send comments regarding this burden estimate or any other aspect of this collection of information, including suggestions for reducing this burden, to: U.S. Citizenship and Immigration Services, Regulatory Coordination Division, Office of Policy and Strategy, 20 Massachusetts Avenue, NW, Washington, DC 20529-2140. OMB No. 1615-0109. Do not mail your completed Form G-1145 to this address.

Complete this form and clip it on top of the first page of your immigration form(s).

Applicant/Petitioner Full Last Name	Applicant/Petitioner Full First Name	Applicant/Petitioner Full Middle Name
E-mail Address		Mobile Phone Number (Text Message)

Form G-1145 09/15/14 Y Page 1 of 1

- Use this form to request a text message and/or email when USCIS accepts your form.
- Form G-1145 can be found on the USCIS webpage: <https://www.uscis.gov/g-1145>.

# What is in an OPT Application?

Be sure you have enough funds in your account to avoid a bounced check. Bounced checks can result in Rejection or Denial of an OPT Application by USCIS.

- ❑ Check for \$410 Fee
  - ❑ Fee can be paid by a personal check, money order, or cashier's check.
  - ❑ It is okay if the name or address in the top left is not the same as the applicant's information.
  - ❑ The check should be made payable to "U.S. Department of Homeland Security."
- ❑ The "memo" or "for" section should state "I-765 OPT Application."
- ❑ Write your SEVIS Number anywhere on the front of the check.

NAME  
ADDRESS  
CITY, STATE ZIP

DATE mm/dd/yyyy

0123  
01-2345/6789

PAY TO THE ORDER OF **U.S. Department of Homeland Security** \$ **410.00**

Four Hundred Ten Dollars and  $\frac{00}{100}$  DOLLARS

BANK NAME  
ADDRESS  
CITY, STATE ZIP

**Your SEVIS Number**

FOR **I-765 OPT Application**

*Your Signature*

⑆012345678⑆ 01234567890123⑆ 0123

# What is in an OPT Application?

- ❑ Original Form I-765

- ❑ Please refer to the “Form I-765 Guide” located on the OPT webpage (same drawer as this “OPT Application Guide”) for step-by-step instructions for how to complete Form I-765.

- ❑ The guidance provided within the “Form I-765 Guide” is an interpretation by ISPO Advisors of the instructions published within the USCIS Instructions for Form I-765. As this guide is a supplement we have created to answer any questions that may arise while completing the Form I-765, we urge all students to also review the guidance provided by [USCIS](#).

# What is in an OPT Application?

## ☐ Photocopy of OPT I-20

- Include copies of all three pages.
- Sign and date the original I-20 but mail the copy.
- Check requested OPT start and end dates on page 2 for accuracy.

### Remember...

- USCIS must receive your OPT Application within 30 days of the Date Issued on page 1 of your OPT I-20.
- USCIS must receive your OPT Application within your 5 months window (no earlier than 90 days before your program end date and no later than 60 days after your program end date).

Department of Homeland Security  
U.S. Immigration and Customs Enforcement

I-20, Certificate of Eligibility for Nonimmigrant Student Status  
OMB NO. 1653-0038

SEVIS ID: [REDACTED]

SURNAME/PRIMARY NAME [REDACTED]	GIVEN NAME [REDACTED]	Class of Admission <b>F-1</b>
PREFERRED NAME [REDACTED]	PASSPORT NAME [REDACTED]	
COUNTRY OF BIRTH [REDACTED]	COUNTRY OF CITIZENSHIP [REDACTED]	ACADEMIC AND LANGUAGE
DATE OF BIRTH [REDACTED]	ADMISSION NUMBER [REDACTED]	
FORM ISSUE REASON [REDACTED]	LEGACY NAME [REDACTED]	

**SCHOOL INFORMATION**

SCHOOL NAME University of California San Diego University of California San Diego	SCHOOL ADDRESS 9500 Gilman Drive, Mail Code 0018, La Jolla, CA 92093
SCHOOL OFFICIAL TO CONTACT UPON ARRIVAL Bunty Kawahara International Student Advisor	SCHOOL CODE AND APPROVAL DATE 90224F0208000 14 JANUARY 2019

**PROGRAM OF STUDY**

EDUCATION LEVEL BACHELOR'S	MAJOR 1 Management Science 52.1301	MAJOR 2 None 90.0000
PROGRAM ENGLISH PROFICIENCY Required	ENGLISH PROFICIENCY NOTES Student in production	EARLIEST ADMISSION DATE
START OF CLASSES 15 SEPTEMBER 2018	PROGRAM START/END DATE 15 SEPTEMBER 2018 - 29 MARCH 2019	

**FINANCIALS**

ESTIMATED AVERAGE COSTS FOR: 12 MONTHS		STUDENT'S FUNDING FOR: 12 MONTHS	
Tuition and Fees	\$ 36,200	Personal Funds	\$ 0
Living Expenses	\$ 20,600	Funds From This School	\$ 0
Expenses of Dependents (C)	\$ 0	Family Funding	\$ 50,000
Books & Supplies	\$ 1,500	On-Campus Employment	\$ 0
TOTAL	\$ 58,300	TOTAL	\$ 50,000

**REMARKS**

**SCHOOL ATTESTATION**

I certify under penalty of perjury that all information provided above was entered before I signed this form and is true and correct. I executed this form in the United States after review and consultation in the United States by me or other officials of the school of the student's application, transcripts or other records of coursework and proof of financial responsibility, which were received at the school prior to the execution of this form. The school has determined that the above named student's qualifications meet all standards for admission to the school and the student will be required to pursue a full program of study as defined by 8 CFR 214.2(f)(6). I am a designated school official of the above named school and am authorized to issue this form.

SIGNATURE OF: Bunty Kawahara, International Student Advisor DATE ISSUED: 31 January 2019 PLACE ISSUED: La Jolla, CA

**STUDENT ATTESTATION**

I have complied with the terms and conditions of my admission and those of any extension of stay. I certify that all information provided on this form is true and correct to the best of my knowledge. I certify that I seek to enter or remain in the United States temporarily, and solely for the purpose of pursuing a full program of study at the school named above. I also authorize the named school to release any information from my records needed by DHS pursuant to 8 CFR 214.3(g) to determine my nonimmigrant status. Parent or guardian, and student, must sign if student is under 18.

SIGNATURE OF: [REDACTED] DATE: [REDACTED]

NAME OF PARENT OR GUARDIAN: [REDACTED] SIGNATURE: [REDACTED] ADDRESS (city/state or province/country): [REDACTED] DATE: [REDACTED]

ICE Form I-20 (3/31/2018) Page 1 of 3

Department of Homeland Security  
U.S. Immigration and Customs Enforcement

I-20, Certificate of Eligibility for Nonimmigrant Student Status  
OMB NO. 1653-0038

INSTRUCTIONS TO STUDENTS

**STUDENT ATTESTATION:** You should read everything on this page carefully. Be sure that you understand the terms and conditions concerning your admission and stay in the United States as a nonimmigrant student before signing the student attestation on page 1 of the Form I-20 A-B. The law provides severe penalties for knowingly and willfully falsifying or concealing a material fact, or using any false document in the submission of this form.

**NOTICE OF ADDRESS:** When you arrive in the United States, you must report your U.S. address to your DSO. If you move, you must notify your DSO of your new address within 10 days of the change of address. The DSO will update SEVIS with your new address.

**REENTRY:** F-1 students may leave the United States and return within a period of five months. To return, you must have: 1) a valid passport; 2) a valid F-1 student visa (unless you are exempt from visa requirements); and 3) your Form I-20, page 2, properly endorsed for re-entry by your DSO. If you have been out of the United States for more than five months, contact your DSO.

Department of Homeland Security  
U.S. Immigration and Customs Enforcement

I-20, Certificate of Eligibility for Nonimmigrant Student Status  
OMB NO. 1653-0038

ID: [REDACTED] NAME: [REDACTED]

**ADDITIONAL AUTHORIZATIONS**

ADDITIONAL OPT	FULL-PART TIME	STATUS	START DATE	END DATE
		REQUESTED	17 APRIL 2017	18 APRIL 2018

**PERIOD OF STATUS/CAP-GAP EXTENSION**

**EXTENDED/REDUCED COURSE LOAD**

**ADDITIONAL SESSION DATES**

ADDITIONAL SESSION START DATE	CURRENT SESSION END DATE
17 APRIL 2017	25 MARCH 2017

**ENDORSEMENT**

When properly endorsed, may be used for re-entry of the student to attend the same school after a temporary absence from the United States. Each endorsement is valid for one year.

School Official	TITLE	SIGNATURE	DATE ISSUED	PLACE ISSUED
		X		
		X		
		X		
		X		

ICE Form I-20 (3/31/2018) Page 2 of 3



# What is in an OPT Application?

- ☐ Photocopy of passport biography page

Be sure the entire MRZ Code is visible.







# What is in an OPT Application?

## ❑ Form I-94

Example of paper I-94 (front and back sides):

Departure Number: 571500107  
U.S. IMMIGRATION AND NATURALIZATION SERVICE  
JAN 29 2003  
CLASS UNTIL D/S  
RELEASED

Record of Changes  
N100081018  
Port: \_\_\_\_\_  
Date: \_\_\_\_\_  
Carrier: \_\_\_\_\_  
Flight #/Ship Name: \_\_\_\_\_

- If you have not travelled into the USA since April 2013 OR if you entered at a land border (such as the land port of entry at Tijuana), then you will have a paper I-94 (example to the left).

- if you travelled into the USA after April 2013 and entered by air or sea, you will have an electronic I-94 record (example to the right). You can retrieve your electronic I-94 record here: [www.cbp.gov/i94](http://www.cbp.gov/i94).

Example of electronic I-94 :

U.S. Customs and Border Protection  
Securing America's Borders  
OMB No 1651-0111  
Expiration Date: 05/31/2015

Get I-94 Information I-94 FAQ

Most Recent I-94

Admission (I-94) Record Number: 54813013030  
Most Recent Date of Entry: 2015 January 05  
Class of Admission: F1  
Admit Until Date: D/S

Details provided on the I-94 information form:

Last Surname: GLOBAL  
First (Given) Name: CITIZEN  
Birth Date: 1992 January 08  
Passport Number: AB002000  
Country of Issuance: Tanzania

U.S. Customs and Border Protection  
Securing America's Borders

Most Recent I-94

Admission (I-94) Record Number : 000468151A1  
Most Recent Date of Entry: 2010 June 10  
Class of Admission : A3  
Admit Until Date : 07/22/2013

Details provided on the I-94 information form:

Last Surname : LF  
First (Given) Name : 06

Note: Beginning May 2019, I-94s will follow the format of 9 digits followed by a two-character alphanumeric series: [9-digit sequence] + [1 letter] + [1 digit].

# What is in an OPT Application?

## ❑ 2 U.S. Passport Photos

- ❑ Photo must be taken within the last 30 days.
- ❑ Photo must be 2"x2". For exact specifications, visit the [U.S. Department of State webpage](#).
- ❑ Lightly print your full name (pen or pencil) AND your SEVIS Number (N000...) on the back of each photo.
- ❑ Photos must be professionally taken.
  - ❑ UCSD Mail Services has a [Passport Acceptance Office](#) that will take passport photos for a fee (no returns).
  - ❑ There are many off-campus locations that offer passport photo services. Please confirm these services follow the [U.S. Department of State](#) regulations.

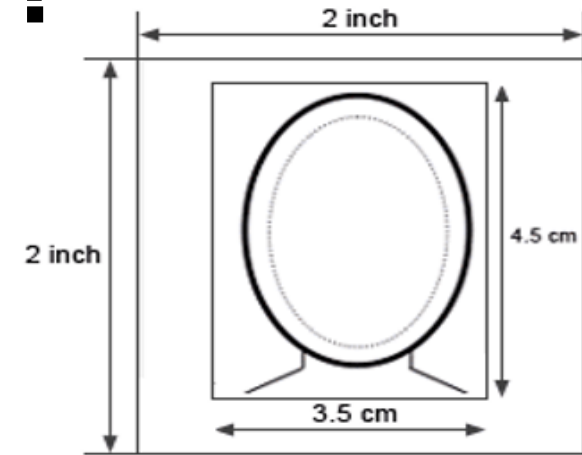

Please return to the OPT webpage for information regarding the timeline and instructions for mailing your OPT Application to USCIS.