



eFile Form I-765: Filing Tips for Post-Completion OPT

A guide for international students at UC San Diego applying for post-completion Optional Practical Training (OPT) online with USCIS.

PURPOSE OF THIS GUIDE

Students are able to submit their Form I-765, Application for Employment Authorization to U.S. Citizenship and Immigration Services (USCIS) through two methods: (1) **Mail**: Downloading, printing, and mailing Form I-765 and other applicable documents and fees to a direct filing address associated with a USCIS Service Center, and (2) **eFile**: Creating a USCIS Online Account and submitting Form I-765 electronically, uploading electronic copies of applicable documents, and paying fees online.

This guide is meant to provide students at UC San Diego with filing tips to file for their initial 12 months of post-completion OPT through eFiling Form I-765.

The information provided in this document does not, and is not intended to, constitute legal advice; instead, all information, content, and materials included are for general informational purposes only and are an interpretation of the instructions published within the [USCIS instructions for Form I-765](#). Students accessing the following content should contact their attorney to obtain advice with respect to any specific legal matter. No reader, user, or viewer of the following content should act or refrain from acting on the basis of information provided without first seeking legal advice from counsel in the relevant jurisdiction. Only your individual attorney can provide assurances that the information contained herein – and your interpretation of it – is applicable or appropriate to your specific situation. All liability with respect to actions taken or not taken based on the contents of this guide and are hereby expressly disclaimed.

APPLICATION SECTIONS

- SECTION 1: Tips before starting your application2**
- SECTION 2: Creating Your Account2**
- SECTION 3: Getting Started2**
- SECTION 4: About You2**
- SECTION 5: Evidence.....3**
 - Document upload quality requirements.....3*
 - Passport Photo3*
 - Form I-944*
 - Employment Authorization Document OR Government ID4*
 - Previously Authorized CPT or OPT5*
 - OPT I-20 with DSO Recommendation5*
- SECTION 6: Additional Information6**
- SECTION 7: Review and Submit7**
 - Avoid Common Mistakes.....7*
 - Review your application8*
 - Application Summary8*
 - Your Statement and Your Signature8*
 - Enter Payment Information8*
 - Final Submission8*
- SECTION 8: Unsolicited Evidence9**

RESOURCES

- [OPT.ucsd.edu](https://opt.ucsd.edu)
- <https://www.uscis.gov/i-765>
- [USCIS Filing Tips for Online Forms:](#)

SECTION 1: TIPS BEFORE STARTING YOUR APPLICATION

- **Requesting I-20 with OPT Recommendation:** Prior to reviewing this guide and starting your I-765 application, ensure you have submitted a request to ISPO for an **OPT I-20** by submitting the F-1 Optional Practical Training (OPT) I-20 Request through [iPortal.ucsd.edu](https://iportal.ucsd.edu).
- **DO NOT** submit your I-765 application online before you receive your **OPT I-20** from ISPO; this is a required document to submit your I-765 OPT Application to USCIS.
- **Questions Not Applicable and Blanks:** The electronic Form I-765 is designed to only ask questions which may be applicable to you based on the answers you provide to previous questions. Answer as many questions as accurately as you can. If the question does not apply to you, LEAVE IT BLANK (no need to write NONE OR N/A).
- **ISPO TIPS:** Throughout the document, locate the  blue lightbulb for helpful filing tips and notes!
- **USCIS Instructions:** Throughout the Form I-765, each page will have a description and instructions on how to properly answer each question in addition to what documents to upload. Read the instructions provided by USCIS within the form for guidance. Note, although the USCIS instructions refer to biometric appointments, please note biometrics are not required for those filing through category (C) (3) (B).

SECTION 2: CREATING YOUR ACCOUNT

- Using a desktop or laptop, open your browser and visit myaccount.uscis.gov to create your account. You may use any email address. One email address per person per account.
- Once you are logged in, go to My USCIS, choose Account Type, and File a Form Online.
- From there choose Application for Employment Authorization (I-765).
- Then click on Start Form.

SECTION 3: GETTING STARTED

- For Eligibility Category, to work after graduation you should choose (c) (3) (B) Student Post-Completion OPT. If you are applying for STEM OPT Extension, please see ISPO's STEM OPT website (stemopt.ucsd.edu) as the contents in this guide are not applicable for you.
- For Premium Processing, answer accordingly.
- For Reason for Applying, answer "Initial permission to accept employment."
- Answer prepare and interpreter information accordingly.

SECTION 4: ABOUT YOU

- Enter information for your name.
 - If you do not have a middle name, leave blank.
-  **Mailing Address Tips:** For "Your contact information", note that the current U.S. mailing address is where your Employment Authorization Document (EAD) will be mailed.
 - If you are using your own address, it is best if you will be at that address for at least the next 3-4 months, which is how long your application may take to process.
 - Another option is to use a friend or family member's address in the U.S., in which case you would enter their name "In care of name." Regardless of what address you enter here, if it does change while your application is pending make sure you update it as soon as possible through your online USCIS account.
 - Note: If you are not using "In care of name", leave blank. Likewise, if you do not have an Address Line 2, also leave blank.
- Enter information for Describe yourself.
- Enter information for when and where you were born.



IMPORTANT: MAKE SURE YOU ENTER YOUR DATE OF BIRTH CORRECTLY.

- Enter information for your immigration information.
 - Note: If you do not have a travel document number, leave blank.



IMPORTANT: MAKE SURE YOU ENTER YOUR SEVIS ID CORRECTLY. Review your Form I-20 to reference your SEVIS ID Number listed at the top of page one (begins with an N).



- Enter Other Information
 - If you have an A-Number and/or USCIS Online Account Number, it will auto-populate; if not check “I do not have or know my number.”



If you do not have an SSN or if you already have an SSN but would like a hard copy replacement, answer “yes” to “Do you want the SSA to issue you a Social Security card”

SECTION 5: EVIDENCE

Document upload quality requirements: The evidence section will ask for you to upload required documents. Ensure that all documents meet the following guidelines in order to be uploaded and accepted by USCIS:

- Clear and readable
- No encrypted or password-protected files
- If your documents are in a foreign language, upload a full English translation and the translator's certification with each original document.
- Accepted characters for file name: English letters, numbers, spaces, periods, hyphens, underscores, and parentheses
- Maximum size: 6MB per file

Passport Photo:

- One 2” x 2” photo of you
- Photo must be taken within the last 30 days.
- Should measure 2 inches by 2 inches, with your face measuring 1 inch to 1 3/8 inch from your chin to the top of your head. Your eyes should be between 1 1/8 inch and 1 3/8 inch from the bottom of the photo. For exact specifications, visit the [U.S. Department of State webpage](https://www.travel.state.gov/visas/index.do). If you need help understanding the photo requirements or want to resize, rotate, or crop your photo, you can use to the Department of State's photo composition tools.
- Make sure your whole face is visible, you are facing the camera directly, and the background is white or off-white. Your head must be bare, unless contrary to your religious beliefs.
- Photos must be professionally taken.
 - UCSD Mail Services has a [Passport Acceptance Office](#) that will take passport photos for a fee (no returns).
 - There are many off-campus locations that offer passport photo services. Please confirm these services follow the U.S. Department of State regulations.

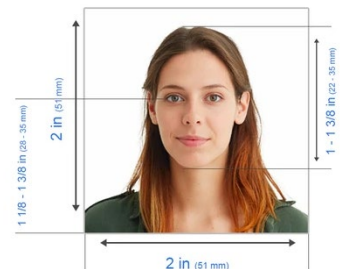
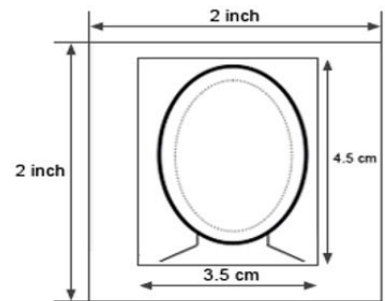

Note, after you submit your application, the photo document may be labeled as an ‘unvalidated photo’ in your documents section. Do not be alarmed, this is to be expected and does not require a new or additional upload. Ensure the photo document that you’ve uploaded meets the above requirements.

Form I-94:

- Make sure you choose "document type"
- If you travelled into the USA after April 2013 and entered by air or sea, you will have an electronic I-94 record (example below). You can retrieve your electronic I-94 record here: www.cbp.gov/i94.
 - Note: Beginning May 2019, I-94s will follow the format of 9 digits followed by a two-character alphanumeric series: [9-digit sequence] + [1 letter] + [1 digit].

- Change of Status to F-1 Within the U.S.: Your Form I-94 may also be at the bottom of your Form I-797A Notice of action. This is a document sent as a replacement for the Form I-94. This typically means that the change of status has been approved and the immigrant is legally able to stay in the U.S. while a decision is made. Form I-94 can be found at the bottom of Form I-797A and functions as the official document.
- If you have not travelled into the USA since April 2013 OR if you entered at a land border (such as the land port of entry at Tijuana), then you will have a paper I-94. See an example of paper I-94 (front and back sides) below:

Employment Authorization Document OR Government ID:

- Upload proof of identity or government issued identification in this section.
- If you have ever engaged in OPT, note you will need to upload your EAD in the following section. In this section, only upload the following:
 - Passport biographical page (most recently issued passport)
 - If different, passport used to last enter the U.S. (See Additional Information)
 - F-1 Visa, if applicable. If your last date of entry to the U.S. was in a different visa type, ensure you upload Form I-797 through the I-94 section.

Previously Authorized CPT or OPT:

- USCIS instructions: Upload a copy of your last Employment Authorization document (EAD) (front and back).
 - If you were previously issued an EAD, upload a copy of front and back here.
- If you have ever previously filed a Form I-765 Application for Employment Authorization and received a receipt notice but were denied or did not pursue your application:
 - Upload Form I-797 Receipt Notice
 - Recommended to explain in Additional Information why you did not pursue OPT (see Additional Information section for more info)
- If you have ever been approved for CPT
 - Upload all copies of CPT I-20(s) or any other proof of authorized employment
 - Recommended to list SEVIS ID, degree level, and CPT authorization dates in Additional Information (see Additional Information section for more info)

OPT I-20 with DSO Recommendation:

- Include copies of all three pages.
- Check to ensure page 2 shows a recommendation for Post-Completion OPT under Employment Authorizations. Ensure it indicates Full-Time.
- Check requested OPT start and end dates on page 2 for accuracy.
- Check to ensure there is a signature from your DSO on page 1 and page 2.
- From iPortal, download the OPT I-20, print it, sign it in the Student Attestation section, then scan it. Upload a copy.



Look at the 'date issued' on page 1 of your OPT I-20. Remember:

- USCIS must receive your OPT Application within 30 days of the Date Issued on page 1 of your OPT I-20.
- USCIS must receive your OPT Application within your 5 months window (no earlier than 90 days before your program end date and no later than 60 days after your program end date).

Department of Homeland Security
U.S. Immigration and Customs Enforcement
I-20, Certificate of Eligibility for Nonimmigrant Student Status
OMB NO. 1653-0038

SEVIS ID: N0001234567

SURNAME-PRIMARY NAME David Appleseed	GIVEN NAME David	CLASS F-1 ACADEMIC AND LANGUAGE
PREFERRED NAME David Appleseed	PASSPORT NAME David	
COUNTRY OF BIRTH USA	COUNTRY OF CITIZENSHIP USA	
DATE OF BIRTH 01/01/2000	ADMISSION NUMBER 0123456789	
FOREVISA REASON MARRIAGE	LEGACY NAME David Appleseed	

SCHOOL INFORMATION

SCHOOL NAME CALIFORNIA STATE UNIVERSITY	SCHOOL ADDRESS 12345 Main Street, Box 0000, CA 95000
SCHOOL OFFICIAL TO CONTACT / P.O. BOX David Appleseed	SCHOOL CODE AND APPROVAL DATE 0123456789

PROGRAM OF STUDY

EDUCATION LEVEL MAJOR 1	MAJOR 2 MAJOR 3
PROGRAM ENGLISH PROFICIENCY Required	ENGLISH PROFICIENCY NOTES Advanced to proficiency

FINANCIALS

ESTIMATED AVERAGE COSTS FOR 12 MONTHS	STUDENT'S FUNDING FOR 9 MONTHS
tuition and fees: \$ 10,000	scholarship: \$ 0
living expenses: \$ 15,000	funds from this school: \$ 0
transportation (if): \$ 1,500	family funding: \$ 0
other resources: \$ 0	the center for international: \$ 0
total: \$ 16,500	total: \$ 0

REMARKS

SCHOOL ATTESTATION

I certify under penalty of perjury that all information provided above was entered before I issued this form and is true and correct. I understand that all information provided on this form is for review and execution in the United States by an official of the school of the student's application, transcript, or other records of review. I understand that the school is responsible for the accuracy of the information provided on this form. I also understand that the school is responsible for the accuracy of the information provided on this form. I am a designated school official of the above named school and am authorized to issue this form.

SIGNATURE OF: David Appleseed, International Student Advisor
DATE ISSUED: 06 January 2016
PLACED ISSUED: Los Angeles, CA

STUDENT ATTESTATION

I have read and agreed to comply with the terms and conditions of my admission and those of any extension of stay. I certify that all information provided on this form is true and correct to the best of my knowledge. I understand that I will be required to maintain my status in the United States throughout my stay and will be responsible for any violation of my status. I also understand that the school is responsible for the accuracy of the information provided on this form. I am a designated school official of the above named school and am authorized to issue this form.

SIGNATURE OF: David Appleseed
DATE:
NAME OF PARENT OR GUARDIAN: _____
SIGNATURE: _____
ADDRESS (city/state or post/zip/country): _____
DATE: _____

ICE Form I-20 A-B (12/2016) Page 1 of 3

Department of Homeland Security
U.S. Immigration and Customs Enforcement
I-20, Certificate of Eligibility for Nonimmigrant Student Status
OMB NO. 1653-0038

SEVIS ID: N0001234567 (F-1) NAME: David Appleseed

EMPLOYMENT AUTHORIZATIONS	TYPE	FULL/PART-TIME	STATUS	START DATE	END DATE
POST-COMPLETION OPT	FULL-TIME	REQUESTED		01 AUGUST 2021	31 JULY 2022

AUTHORIZED REDUCED COURSE LOAD

CURRENT SESSION DATES

CURRENT SESSION START DATE 01 JANUARY 2016	CURRENT SESSION END DATE 24 MARCH 2016
--	--

TRAVEL ENDORSEMENTS

This page, when properly endorsed, may be used for re-entry of the student to attend the same school after a temporary absence from the United States. Each endorsement is valid for one year.

Designated School Official	TITLE	SIGNATURE	DATE ISSUED	PLACED ISSUED
David Appleseed	International Student Advisor	[Signature]	06/01/2016	Los Angeles

ICE Form I-20 A-B (12/2016) Page 2 of 3

SECTION 6: ADDITIONAL INFORMATION

You may need to provide additional information in this section with additional evidence. See the following examples of additional information required. If none apply to you, click next. If any of these apply to you, you must fill in Additional Information as indicated with the following examples and also attach supporting documents in the appropriate section.

Example A: If you have ever previously filed a Form I-765 Application for Employment but not approved

- **Refers to:** Getting Started, Reason for applying, Question “Have you previously filed Form I-765?”
- **Attach (in section Unsolicited Evidence after Submission):** Form I-797 Receipt Notice and written explanation regarding why you did not pursue OPT, Form I-797 Notice of Action showing denial and reason for denial.
- **Additional Information:** I-765 Filed on MM/DD/YYYY. I did not pursue my I-765 Application because I transferred to another institution before my application was adjudicated. Please see my receipt notice of pending I-765. - **OR-:**
- **Additional Information:** My I-765 application was denied on MM/DD/YYYY. Please see receipt notice of pending I-765 and my notice of denial.

Example B: If you have ever been approved for OPT and received an EAD card.

- **Refers to:** Getting Started, Reason for applying, Question “Have you previously filed Form I-765?”
- **Attach (in section Previously Authorized CPT or OPT):** All copies of EAD cards
- **Additional Information:** For each EAD card received, list corresponding SEVIS ID, degree level, and authorization dates. For example:
 - N001111111 – Bachelor Level. OPT authorized from MM/DD/YYYY to MM/DD/YYYY. See EAD card attached.
 - N001111111 – Master Level. OPT authorized from MM/DD/YYYY to MM/DD/YYYY. See EAD card attached.

Example C: If you have ever been approved for CPT

- **Refers to:** About You, Your Immigration Information, What is your SEVIS Number?
- **Attach (in section Previously Authorized CPT or OPT):** All copies of CPT I-20(s)
- **Additional Information:** N001111111 – Bachelor Level. CPT authorized from MM/DD/YYYY to MM/DD/YYYY. See CPT I-20 reflecting authorization.

Example D: If you have ever been issued a different SEVIS ID Number that did not have any authorized CPT or OPT.

- **Refers to:** About You, Your Immigration Information, What is your SEVIS Number?
- **Attach (in section Unsolicited Evidence after Submission):** A copy of the Form I-20 or DS-2019 showing your SEVIS ID Number.
- **Additional Information:** N001111111 – Associate Level. No CPT or OPT was authorized on this SEVIS number.

Example E: If your most recently issued passport is not the passport you last used to enter the U.S.

- **Refers to:** About You, Your Immigration Information, What is the passport number of your most recently issued passport?
- **Attach (should already be in EAD or Government ID Section):** A copy of your most recently issued passport
- **Additional Information:** I renewed my passport at an embassy/consulate here in the United States after the date of my last entry. Please see a copy of attached of my new passport.

Example F: If your last date and port of entry was through a land border, such as Mexico or Canada, and I-94 does not reflect the entry.

- **Refers to:** About You, Your Immigration Information, When did you last arrive in the United States?
- **Attach (in Form I-94 section):** Travel History page of your electronic I-94 reflecting land border entry and, if available, copy of entry stamp within passport matching same date/port of entry.
- **Additional Information:** My last port of entry was through Mexico. This is not reflected on my Form I-94, but shows on the Travel History page. Please see the Travel History page attached along with the stamp of entry in my passport.

Example G: If you have had any previously used legal names

- **Refers to:** About You, Your name, Have you used any other names since birth?
- **Attach (in EAD or Government ID section):** Copy of government or foreign government issued documentation showing legal name or name change
- **Additional Information:** Please see the foreign government issued documentation attached which shows my previous legal name and/or new name change.

Example H: If you hold dual citizenship

- **Refers to:** About You, Your immigration information, What is your country of citizenship or nationality?
- **Attach (in EAD or Government ID section):** Copy of passport of foreign government issued documentation showing citizenship
- **Additional Information:** I am a dual citizen from both the countries of Oceano and Pacifica. Please see copies of my passport from both countries attached.

Example I: You last entered the U.S. in a different status (not F-1) and changed status to F-1 from within the U.S. and received Form I-797A Notice of action showing approval of your F-1 Status.

- **Refers to:** About You, Your Immigration Information, When did you last arrive in the United States?
- **Attach (in I-94 section):** Form I-797 with Form I-94 attached at the bottom.
- **Additional Information:** I last entered the U.S. through a different classification and recently changed status using Form I-539 with USCIS to F-1. The I-797 Notice of Action reflects the approval of my F-1 Status and Form I-94 at the bottom.

SECTION 7: REVIEW AND SUBMIT

Avoid Common Mistakes

- In order to avoid complications, delays or denials of your OPT Application, review the tips below and make a final check of your application before paying and submitting to USCIS. Make sure that:
 - **DO NOT SUBMIT THIS APPLICATION until you have received your OPT I-20 with a recommendation listed on page 2 of your Form I-20 from ISPO.**
 - **USCIS requires that applicants be physically present in the U.S. at the time of submitting their OPT Application.**

- USCIS receives your OPT application no later than 30 days after the Date Issued on Page 1 of your OPT I-20. If USCIS does not receive your OPT Application within the 30 days after the Date Issued, ISPO must issue you're an updated OPT I-20 (Submit a Replacement I-20 Request in iPortal) in order to restart the 30-day window.
 - USCIS receives your OPT application within your [5 month eligibility window](#):
 - No earlier than 90 days before the end of your program completion date
 - No later than 60 days after the end of your program completion date
 - Double check the documents you are uploading. Ensure that you sign your OPT I-20 and that all documents are uploaded in appropriate sections within evidence.
-  If filing close to any deadlines, note that USCIS operates on Universal Coordinated Time (UTC) which is 7 hours ahead of Pacific Standard Time. Ensure all applications are complete and submitted before **4:59 PM PST** of the current day in order for it to be considered as submitted on that day.

Review your application

- Check for alerts – if there are any **red** or **yellow** alerts, make appropriate edits
- Move on to “Your application summary” when you have a green alert that says “We found no alerts or warnings in your application”

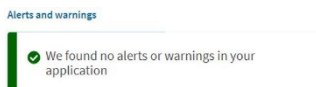

Application Summary

- Review all your answers on this page. If you want to make any changes, click the appropriate section (i.e. Evidence) on the top left.
- You can click “print” for a print out of this page.
- You can also click “View draft snapshot” for Electronic Form version of I-765 (not to be sent to USCIS)

Your Statement and Your Signature

- On “Your Statement”, read and click the check mark for Applicant’s Statement
- On “Your Signature”, read Applicant’s Declaration and Certification click the check mark, and sign by typing your full legal name under Applicant’s signature. USCIS will record the date of your signature with your application.

Enter Payment Information

- The amount due will show on the screen. Click the box “pay and submit.”
- Choose payment method and enter appropriate information.



NOTE: The Pay.gov website processes and post-dates payments to the next business day. You will not be able to submit your application until the payment information is received. Thus, as long as your application has been submitted on time, the Pay.gov payment date being post-dated is not a problem.



IMPORTANT NOTE:



Only click the “CONTINUE” button when you are ready to submit. This is the final step!

Final Submission

The application will be considered as submitted once you click ‘CONTINUE’. After final submission, you may not make edits to your responses or previously uploaded document. To add additional document corresponding to Additional Information, see next section.

- **Receipt Notice:** Immediately after submission, you will receive a PDF copy of your I-797C Receipt Notice of Action. This will contain your receipt number and information regarding when USCIS received your application. Refer to the information on this receipt notice to follow up on the status of your application. Note, this document will also be mailed to you at the mailing address you provided in your I-765 application.

SECTION 8: UNSOLICITED EVIDENCE

Within Additional Information, some examples may have applied to you in which a required document must be attached in the Unsolicited Evidence section. This can only be done once the application has been submitted to USCIS. Ensure that you upload any applicable documents here.

If you have any questions regarding your application after you have submitted, please visit [OPT.ucsd.edu](https://opt.ucsd.edu) ([STAGE 3: MAINTAINING F-1 STATUS WHEN OPT IS PENDING](#))